

Vector

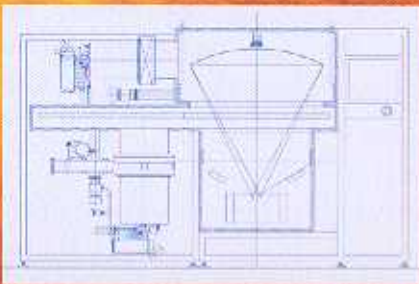

Vector
*High Vacuum
Lift-off Evaporator*

System Control Technology has designed a high vacuum deposition system whose principal feature is its large source to substrate distance—48 inches—which allows it to perform true liftoff on six inch substrates.

The Vector is a load lock box type evaporator completely enclosed in an electropolished stainless steel cabinet. The system is designed for easy integration into a clean room and allows easy access to all controls.

The Vector has been designed with flexibility in mind, and can accommodate a large variety of vapor deposition equipment deployed in custom configurations. The evaporation source chamber is maintained under high vacuum at all times. By doing this, we reduce substrate contamination during evaporation, and achieve higher evaporation rates

as a result of vacuum degas of source material, resulting in a superior product.

Programmable High Vacuum System Controller with Data Logging Capabilities

SCI provides as a standard a GE Fanuc PLC industrial controller. This system includes ladder logic software with required programming for the SCI Vector. The operator/engineer computer interface includes a GE Fanuc Display Station 2000 (GE 15" touch screen computer); GE "Cimplicity" HMI, or equivalent and all required software programming are also provided. The control system also performs data logging of all key process variables.

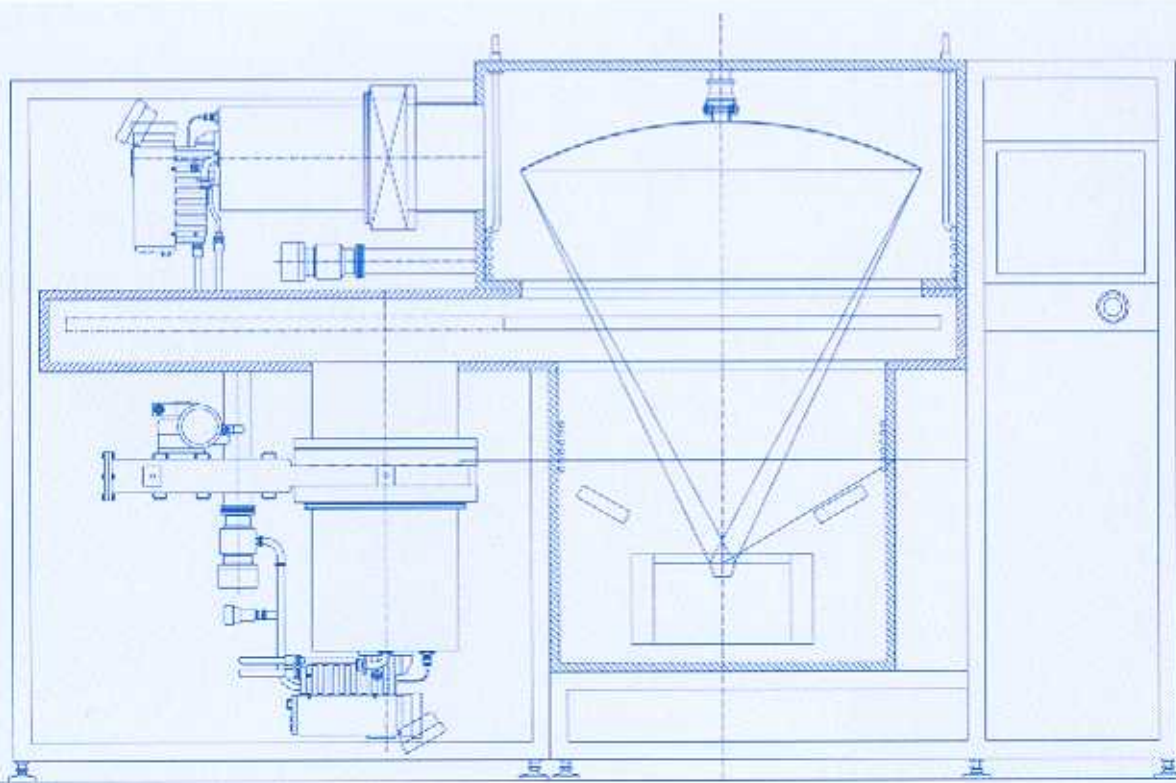

VECTOR INNARDS—This CAD drawing presents a sectional front view of the Vector. Of note are the new six-pocket, 100cc e-gun, the 48" source-to-substrate distance, and the load lock design for faster pump down.